

4x4[®] Pneumatic Actuator

WHY SMALLER IS BETTER

The Sharpe Pneumatic Actuator Series 4x4[®] packs more than double the torque of conventional rack and pinion actuators. Due to its four pistons that generate torque around a centrally located pinion. With more pistons in the actuator, it allows their diameter to be smaller while generating higher torque. At the same time, it means the size of the actuator can be more compact.

WHY SMALLER IS FASTER

With four small cylinders each located on one of four sides of the unit and at a given air pressure, the 4x4[®] produces the same torque output as double piston models using smaller diameter pistons and a narrower pinion. Thanks to the narrower pinion, the pistons travel shorter distances so that they can move faster from one position to the next.

WHY SMALLER REDUCES AIR CONSUMPTION

The cube shape coupled with pistons traveling shorter distances minimizes size requirements while maximizing torque output. At the same time, shorter piston travel and compact size greatly reduces pressure requirements compared to other designs and results in reduced energy expenditures.



WHY SMALLER MEANS LESS STRESS

It's a matter of balance. Unlike other designs that produce an off-axis thrust, the 4x4[®] design positions each piston around the cube so they develop thrust along their own axis. As a result, stressful piston side loading is minimized putting less stress on seals resulting in less wear.

WHY SMALLER IS A BETTER SOLUTION

Because of the four-cylinder design, the 4x4[®] has many more spring combination possibilities than double piston actuators. This means better solutions under any air pressure requirement. Each chamber can use up to three different spring sizes which nest between the covers and pistons and align by centering rings. Also, springs are wound in opposite directions to avoid tangles during operation.

WHY SMALLER IS STRONGER

For superior corrosion resistance, the body and covers are anodized internally and externally. Plus, they have an external epoxy base layer and a second polyurethane paint to further reduce corrosion in demanding applications. Extended spray wash downs do not create corrosion problems for the actuator.

4x4[®] Material Listing

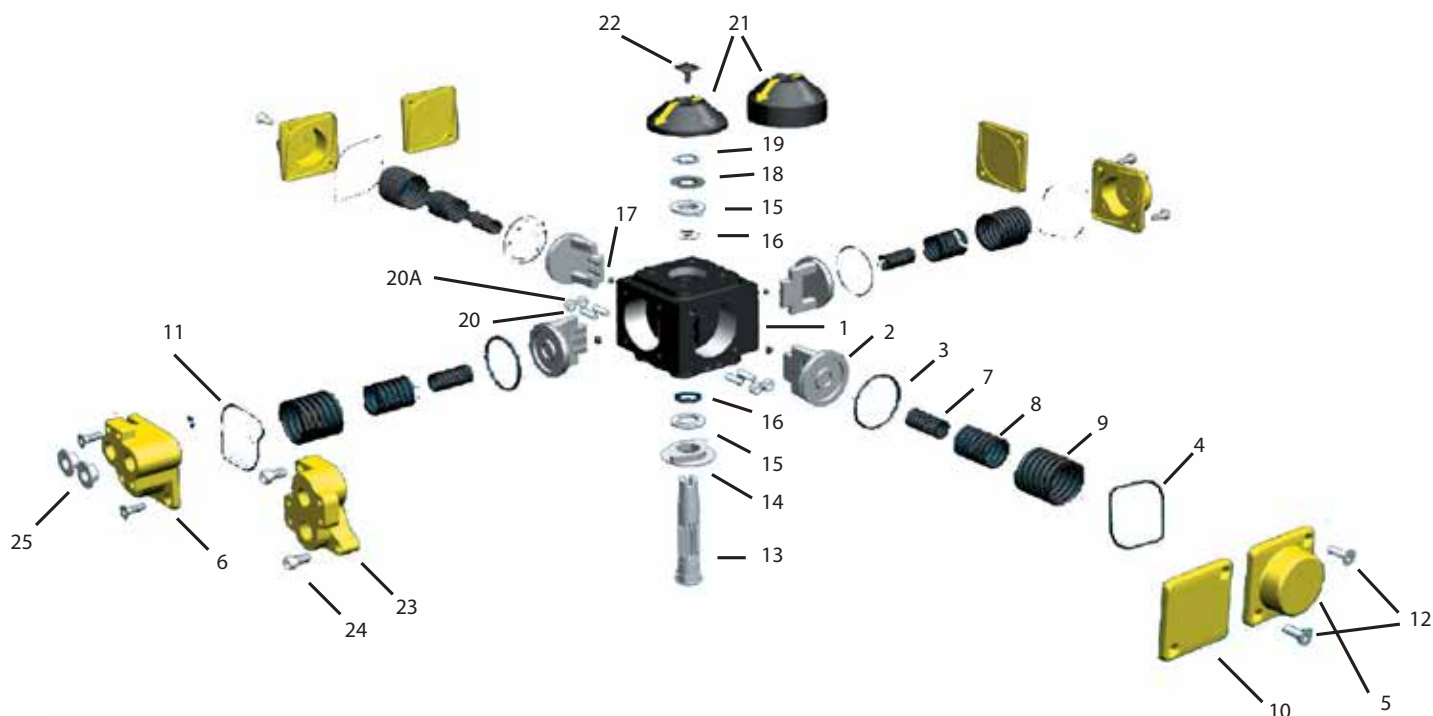

Part No.	Qty	Part Description	Standard Materials
1	1	Body	Aluminum AL 356-T6
2	4	Piston	Carbon Steel S45C Nickel Plated
3*	4	Piston "O" Ring	BUNA / Viton
4*	4	Cover "O" Ring	BUNA / Viton
5	3	Spring Return Cover	Aluminum AL 380
6	1	NAMUR Cover	Aluminum AL 380
7	Max 4	Inner Spring	Painted Spring Steel
8	Max 4	Middle Spring	Painted Spring Steel
9	Max 4	Outer Spring	Painted Spring Steel
10	3	Double Acting Cover	Aluminum AL 380
11	1	Air Supply "O" Ring	BUNA / Viton
12	8,16 or 18	Cover Screw	Stainless Steel 304
13	1	Pinion	Steel
14	1	Stroke Adjustment Stop	Stainless Steel 304
15*	2	Thrust Washer	POM
16*	2	Pinion "O" Ring	BUNA / Viton
17*	4	Pad	POM
18*	1	Disc Bearing	Stainless Steel 304
19	1	Snap Ring	Stainless Steel 304
20	4	Stroke Adjustment Stud	Stainless Steel 304
20A	4	Nut	Stainless Steel 304
21	1	Indicator	ABS
22	1	Indicator Screw	C15
23	1	NAMUR Insert (X115)	AL 380
24	2	Bolt (X115)	Stainless Steel 304
25	2	Plug	Plastic

* Parts Typically supplied in service kits

4x4[®] Dimensions

SPRING RETURN

X40 - X90

X115

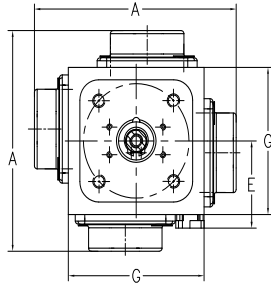
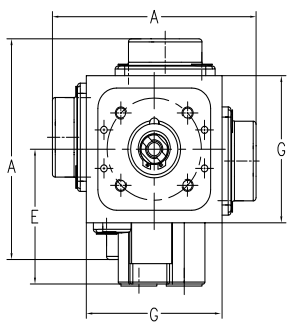

G-1/4" ISO
(FOR METRIC)
1/4" NPT
(FOR IMPERIAL)

M5 (FOR METRIC)
10/24 UNC
(FOR IMPERIAL)

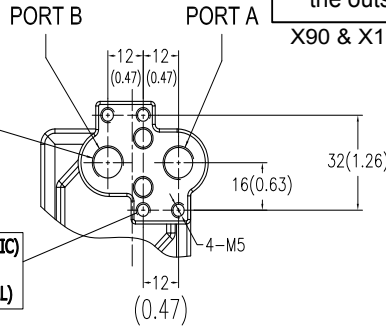

PORT A connected to
the center chambers
PORT B connected to
the outside chambers
X90 & X115 are opposite

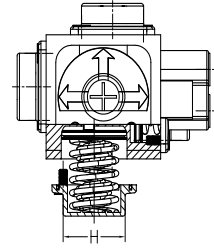

DOUBLE ACTING

X40 - X90

X115

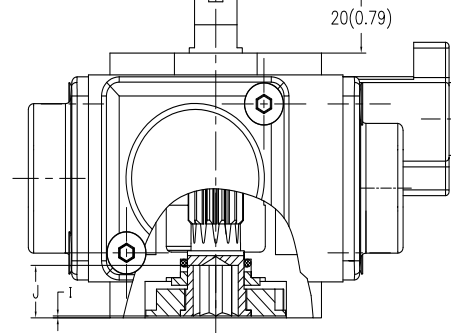
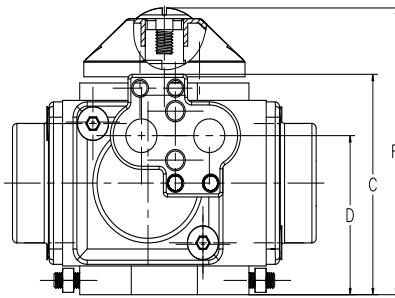
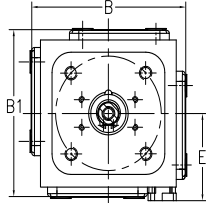
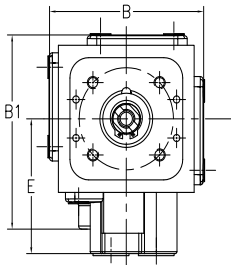

Size	Unit	A (S/R)	B (D/A)	B1 (D/A)	C	D	E	F	G	H	I	J
X40	in	4.26	3.31	3.78	2.73	2.04	2.60	3.65	2.84	1.61	0.02	0.55
	mm	108	84	96	69	52	66	92	72	40	0.5	14
X50	in	5.26	4.04	4.63	3.15	2.50	3.05	4.08	3.47	2.00	0.02	0.61
	mm	133	102	117	80	63	77	103	88	51	0.5	15
X60	in	6.38	5.20	5.79	3.86	3.02	3.53	4.73	4.26	2.50	0.02	0.77
	mm	162	132	147	98	77	89	120	108	63	0.5	20
X75	in	7.41	5.99	6.70	4.65	3.67	3.75	5.46	4.97	2.99	0.02	0.89
	mm	188	152	170	118	93	95	138	126	76	0.5	22
X90	in	8.75	7.17	7.96	5.36	4.04	4.49	6.17	5.91	3.59	0.02	1.04
	mm	222	182	202	136	102	114	156	150	91	0.5	26
X115	in	10.71	8.75	8.75	6.50	4.70	4.41	7.45	7.25	4.50	0.02	1.28
	mm	272	222	222	165	119	112	189	184	114	0.5	32

4x4[®] Dimensions

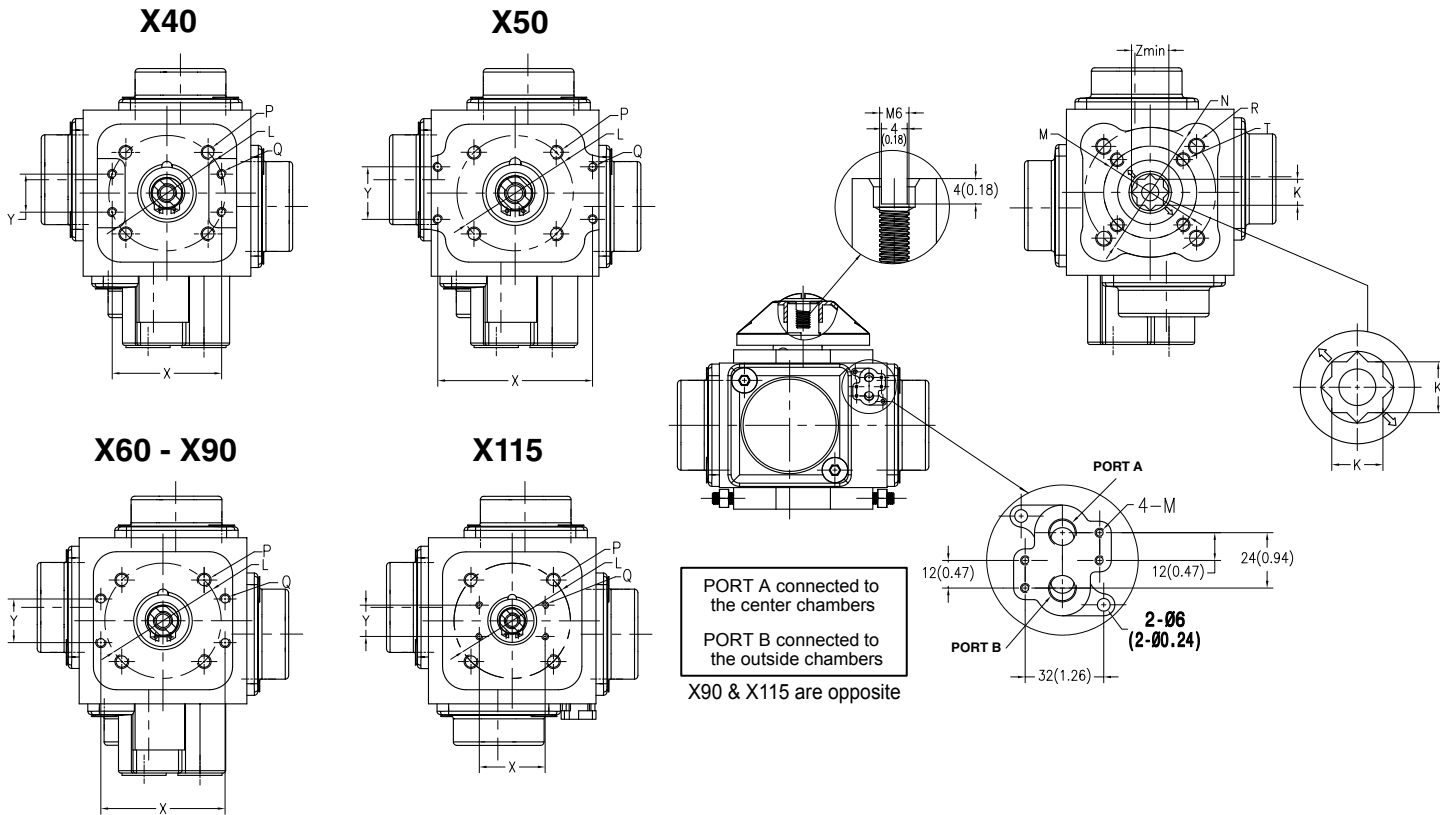

Size	Unit	K	L	M	N	P	Q	R	T	W	X	Y	Z (min)
X40	in	0.35	F05	-	F05	1/4	-	1/4	-	1.61	1.85	0.67	0.48
	mm	9	F05	-	F05	M6	M4	M6	-	40	47	17	12
X50	in	0.43	F05	F05	F07	1/4	10-24 UNC	5/16	1/4	2.00	3.15	1.18	0.56
	mm	11	F05	F05	F07	M6	M5	M8	M6	51	80	30	14
X60	in	0.55	F07	F07	F10	5/16	10-24 UNC	3/8	5/16	2.50	3.15	1.18	0.72
	mm	14	F07	F07	F10	M8	M5	M10	M8	63	80	30	18
X75	in	0.67	F07	F07	F10	5/16	10-24 UNC	3/8	5/16	2.99	3.15	1.18	0.87
	mm	17	F07	F07	F10	M8	M5	M10	M8	76	80	30	22
X90	in	0.87	F10	-	F10	3/8	10-24 UNC	3/8	-	3.59	3.15	1.18	1.11
	mm	22	F10	-	F10	M10	M5	M10	-	91	80	30	28
X115	in	1.06	F12	-	F12	1/2	10-24 UNC	1/2	-	4.50	3.15	1.18	1.43
	mm	27	F12	-	F12	M12	M5	M12	-	114	80	30	36

4x4[®] Spring Arrangement

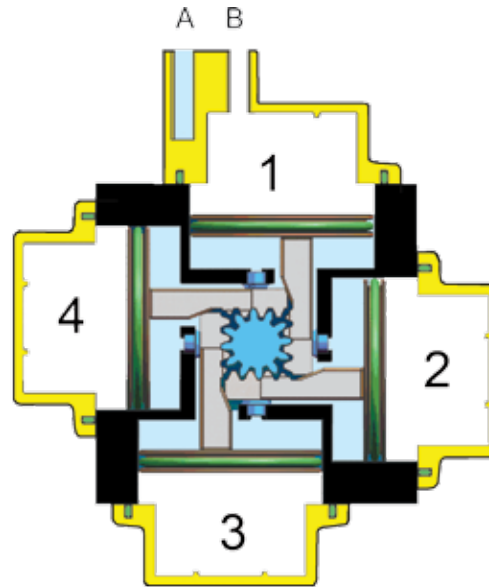

Spring Arrangement	Spring Position	Chamber			
		1	2	3	4
01	Inner	X	X	X	X
	Middle	-	-	-	-
	Outer	-	-	-	-
02	Inner				
	Middle	X	X	X	X
	Outer	-	-	-	-
03	Inner	X	-	X	-
	Middle	X	X	X	X
	Outer	-	-	-	-
04	Inner	X	X	X	X
	Middle	X	X	X	X
	Outer	-	-	-	-
05	Inner	X	X	X	X
	Middle	-	X	-	X
	Outer	X	-	X	-
06	Inner	X	X	X	X
	Middle	-	-	-	-
	Outer	X	X	X	X
07	Inner	X	X	X	X
	Middle	X	X	X	X
	Outer	X	-	X	-
08	Inner	-	-	-	-
	Middle	X	X	X	X
	Outer	X	X	X	X
09	Inner	X	-	X	-
	Middle	X	X	X	X
	Outer	X	X	X	X
10	Inner	X	X	X	X
	Middle	X	X	X	X
	Outer	X	X	X	X

4x4® Torques

4x4® Spring Return Torques																	
Model	Spring Arrangement	Air Supply														Spring Return	
		40 PSI		60 PSI		70 PSI		80 PSI		90 PSI		100 PSI		120 PSI			
		Start	End	Start	End	Start	End	Start	End	Start	End	Start	End	Start	End	Start	End
X40	01	52	29	90	64	116	92	136	112	155	130	170	146	215	188	52	30
	02			73	39	100	68	120	87	138	104	154	121	196	159	78	46
	03					84	44	103	62	120	78	137	97	178	131	104	64
	04									104	52	122	72	159	105	130	82
X50	03	82	40	156	108	206	160	244	194	275	224	316	267	389	335	110	67
	04			140	86	193	139	230	173	260	200	303	246	376	313	132	81
	05			122	60	176	114	215	148	242	174	286	220	358	288	158	98
	06					160	89	195	122	226	150	269	196	340	262	185	116
	07					146	79	182	113	211	139	255	186	325	250	196	131
	08							170	89	199	114	243	163	313	226	219	144
	09									188	101	231	149	300	213	234	156
X60	03	204	119	347	249	439	343	519	417	590	485	672	570	818	723	205	118
	04			325	210	419	308	496	379	568	447	651	534	796	684	245	141
	05			305	177	400	275	476	346	547	413	632	502	777	650	279	161
	06					373	237	450	306	520	372	606	462	749	609	320	188
	07					350	193	425	260	495	325	583	418	724	561	368	214
	08							400	219	470	284	559	379	699	519	409	238
	09									452	231	542	229	683	466	461	256
X75	03	235	212	563	432	729	600	859	722	976	834	1126	986	1382	1255	305	189
	04	290	153	520	367	688	538	817	658	933	769	1085	924	1339	1189	370	232
	05			475	270	646	448	772	563	888	673	1042	832	1294	1091	466	277
	06			436	164	603	372	728	486	843	595	999	758	1249	1012	546	323
	07					569	313	693	424	807	531	966	697	1214	948	610	358
	08					552	216	657	348	772	454	931	624	1178	869	686	393
	09									725	368	888	542	1132	781	774	440
X90	03	656	405	1071	780	1346	1061	1559	1260	1748	1439	1995	1692	2428	2146	544	283
	04			1014	678	1291	965	1502	1159	1690	1337	1940	1594	2371	2042	648	340
	05			915	562	1198	855	1405	1045	1592	1221	1845	1484	2273	1925	963	439
	06					1122	703	1326	888	1511	1061	1769	1332	2192	1762	924	519
	07					1061	575	1263	754	1447	926	1708	1203	2129	1625	1065	582
	08							1193	613	1376	782	1640	1065	2059	1478	1206	653
	09									1298	579	1567	968	1980	1375	1309	730
X115	03	1196	645	2019	1437	2542	1975	2968	2370	3347	2732	3820	3218	4652	4087	1167	643
	04			1890	1206	2419	1756	2841	2143	3218	2500	3697	2997	4524	3852	1400	772
	05			1791	1027	2325	1586	2743	1967	3118	2322	3602	2827	4428	3670	1582	870
	06					2174	1318	2585	1687	2959	2038	3450	2558	4264	3382	1866	1030
	07					2051	1097	2458	1458	2828	1805	3325	2336	4136	3147	2100	1160
	08							2330	1230	2699	1574	3203	2115	4007	2910	2335	1289
	09									2573	1341	3083	1894	3881	2675	2568	1414
10									2444	1110	2960	1673	3754	2440	2800	1543	

4x4® Double Acting Torque Ratings							
Model	40 PSI	60 PSI	70 PSI	80 PSI	90 PSI	100 PSI	120 PSI
X40	79	119	137	178	192	218	238
X50	138	230	265	302	339	375	458
X60	315	470	550	657	725	799	959
X75	537	824	948	1074	1208	1340	1648
X90	920	1400	1666	2060	2130	2354	2893
X115	1953	2838	3322	3817	4302	4620	5401

4x4[®] Weights and Technical Information

4x4 [®] Weights							
	Unit	X40	X50	X60	X75	X90	X115
Weight of Double Acting	Lb	2.38	3.86	6.81	10.69	16.42	28.66
	Kg	1.08	1.75	3.09	4.85	7.45	13.00
Weight of Double Acting with SR Cover (DS)	Lb	2.42	3.96	6.97	11.16	17.17	29.78
	Kg	1.10	1.80	3.16	5.06	7.79	13.51
Spring Set Code	Weight of Spring Return Actuator						
01	Lb	2.51	-	-	-	-	-
	Kg	1.14	-	-	-	-	-
02	Lb	2.60	-	-	-	-	-
	Kg	1.18	-	-	-	-	-
03	Lb	2.67	4.17	7.50	12.19	18.92	33.27
	Kg	1.21	1.89	3.40	5.52	8.58	15.09
04	Lb	2.73	4.21	7.58	12.35	19.22	33.91
	Kg	1.24	1.91	3.44	5.60	8.72	15.38
05	Lb	-	4.30	7.76	12.63	19.69	34.55
	Kg	-	1.95	3.52	5.73	8.93	15.67
06	Lb	-	4.39	7.94	12.92	20.15	35.19
	Kg	-	1.99	3.60	5.86	9.14	15.96
07	Lb	-	4.43	7.98	13.07	20.39	35.98
	Kg	-	2.01	3.62	5.93	9.25	16.32
08	Lb	-	4.52	8.20	13.47	20.92	36.77
	Kg	-	2.05	3.72	6.11	9.49	16.68
09	Lb	-	4.56	8.29	13.62	21.25	37.41
	Kg	-	2.07	3.76	6.18	9.64	16.97
10	Lb	-	4.63	8.38	13.78	21.56	38.03
	Kg	-	2.10	3.80	6.25	9.78	17.25

4x4 [®] Air Consumption & Opening and Closing Times							
	Unit	X40	X50	X60	X75	X90	X115
Air Consumption Per Stroke * Actual Volume - Liter	CCW	0.08	0.15	0.29	0.47	0.80	1.3
	CW	0.11	0.19	0.38	0.64	0.95	1.3
	Total	0.19	0.34	0.67	1.11	1.75	2.6
Air Consumption Per Stroke * Actual Volume - in ³	CCW	4.9	9.2	16.2	28.7	46.3	79.3
	CW	6.7	11.6	21.3	35.1	52.3	82.6
	Total	11.6	20.7	37.5	63.8	98.6	161.9
Opening Time DA**	Sec.	0.15	0.21	0.39	0.53	1.10	1.60
Closing Time DA**	Sec.	0.16	0.24	0.41	0.54	1.30	1.80

* If you plan to use the actuator with the spring return cover as double acting actuator; please consult your representative for the air consumption figures

** The above indicated moving time of the actuator, are obtained in the following testcons: (1) Room Temperature, (2) Actuator Stroke 90° (3) Solenoid Valve with orifice of 4mm and flow capacity Qn 400/L/min. (4) Inside pipe diameter 8mm, (5) Medium clean air, (6) Air supply pressure 5.5 bar (79, 75psi), (7) Actuator without external resistance load. Cautions: on the field applications when one or more of the above parameters are different, the moving time will be different.

4x4[®] Ordering Information

4x4[®] Sample Specification

Actuator shall be Sharpe Automation X series (4x4[®]) with four piston design and function. Actuator will have epoxy coated end caps, with hard anodized internally and externally extruded aluminum body. Internal parts to feature four carbon steel pistons for strength and have electroless nickel plating to inhibit corrosion. Actuator will have a higher torque output than other designs with comparable cylinder bores allowing for fitting of the smallest size possible.

With its smaller design air consumption will be reduced due to less open space in the actuator. Actuator will have four pistons supporting the pinion for less wear. With this design, torque output is maximized. With its design travel is reduced leading to quicker response and less wear to moving parts.

Springs are nested and wound in opposite direction to prevent binding. Since there are four chambers many spring combinations are available to fit air supply issues in the application. Independent travel stops allow adjustment +/- 5° in both opening and closing rotations.

All bottom bolting to ISO 5211 for ease of usage with valves / mounting kits of industry standards. Actuators to have NAMUR mount solenoid connections as well as other top mounted devices such as limit switches and positioners.

Lubrication to qualify for a minimum of 1,000,000 operations. Bearings, bushings and o-rings designed to maximize service life and prevent premature failure.

Fig: X90-SR-07-M

Description: X90 - Spring Return - 07 Spring Arrangement - Metric Units

4x4 [®] Part Number Chart							
Actuator Model	Action		Spring Arrangement	Insert		Options	
X40	DA	Double Acting	01, 02	M	Metric	P1	High Temp EPDM Seals -40°F to 300°F Reverse Rotation
X50	SR	Spring Return	03, 04			P4	
X60	DS	Double Acting with Spring Return Cover	05, 06				
X75			07, 08				
X90			09, 10				
X115							